

◎ 飛剪範例程式 (Ex2n1PG)

◆ 接線圖

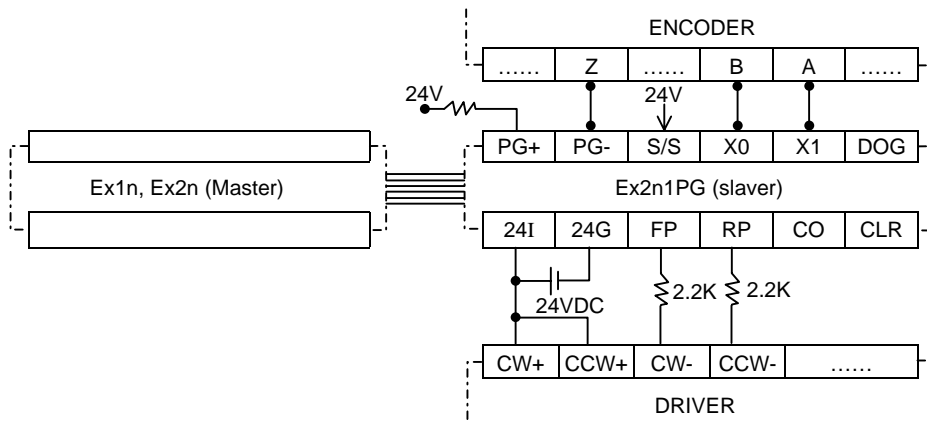

◆ 程式

```

M8003
| |-----[CALL P58 ]
M8003
| |-----[FROM K0 K28 D128 K1 ] 讀取 1PG 狀態
M8003
| |-----[TO K0 K25 K4M600 K1 ] 運轉命令
X014
| |----- ( M614 ) 飛剪追剪運轉開始
X014
| |----- ( M601 ) 1PG STOP
| |-----[ FEND ]
M8000
| |-----[TOP K0 K3 H2108 K1 ] BFM#03 : Parameter
| |-----[DTOP K0 K4 K10000 K1 ] Max. High speed
| |-----[TOP K0 K6 K100 K1 ] bias speed
| |-----[TOP K0 K15 K200 K1 ] Acceleration slope
M8000
| |-----[DTOP K0 K17 K400 K1 ] Target(1)裁剪總長脈波數
| |-----[DTOP K0 K19 K-5000 K1 ] Speed(1)
| |-----[DTOP K0 K21 K100 K1 ] Target(2)同步脈波數
| |-----[DTOP K0 K23 K1000 K1 ] Speed(2)
M8000
| |-----[TOP K0 K92 K400 K1 ] Electronic gear (cmx.)
| |-----[TOP K0 K93 K600 K1 ] Electronic gear (cdv.)
M8000
| |-----[DTOP K0 K83 K300 K1 ]
M8000
| |-----[FROM K0 K30 D130 K1 ] read version
| |-----[ SRET ]
| |-----[ END ]
    
```