

◎ 補間

◆圖示：

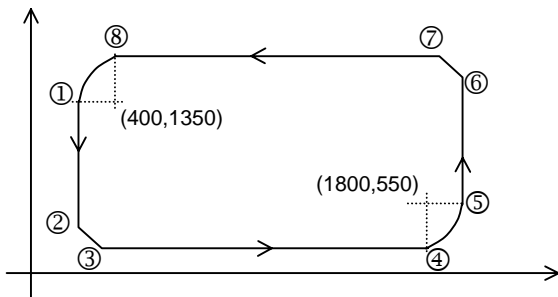

◆動作說明

- ①→②：僅 Y 軸由(250,1350) → (250,550)
- ②→③：直線補間，由(250,550) → (400,400)
- ③→④：僅 X 軸由(400,400) → (1800,400)
- ④→⑤：圓弧補間由(1800,400) → (1950,550)
- ⑤→⑥：僅 Y 軸，由(1950,550) → (1950,1350)
- ⑥→⑦：直線補間，由(1950,1350) → (1800,1500)
- ⑦→⑧：僅 X 軸由(1800,1500) → (400,1500)
- ⑧→①：圓弧補間由(400,1500) → (250,1350)

◆接線圖

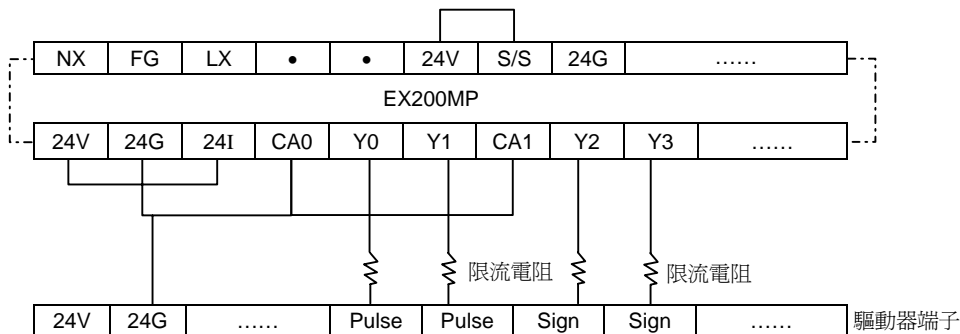

◆程式

