

## ⊙ Without Target Running with Slope Speed-change (PLSV)

### ◆ Diagram ( I ) Without target running with slope speed-change

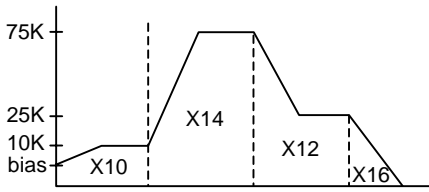

### ◆ Diagram ( II ) Without target running without slope speed-change

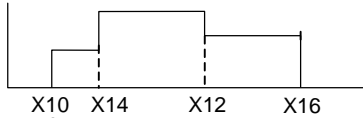

### ◆ Instruction:

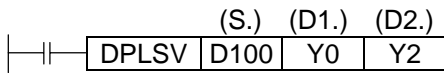

### ◆ Wiring

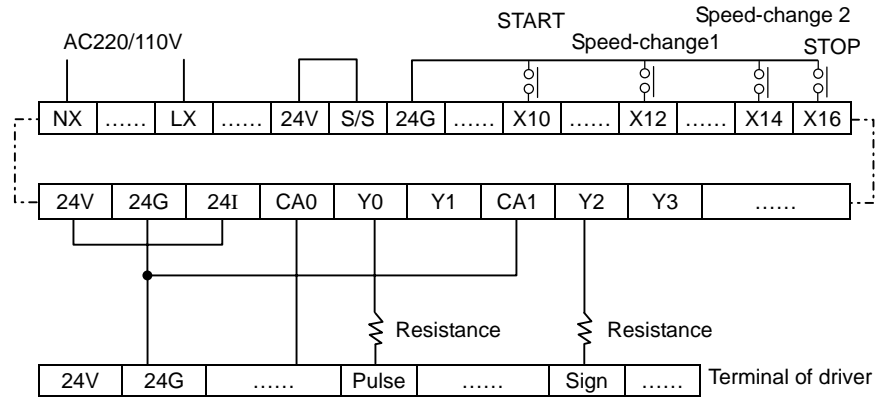

### ◆ Action description

X10 ↓↓ - Start    X12 ↓↓ - Speed-change    X14 ↓↓ - Speed-change    X16 ↓↓ - Stop

### ◆ Program

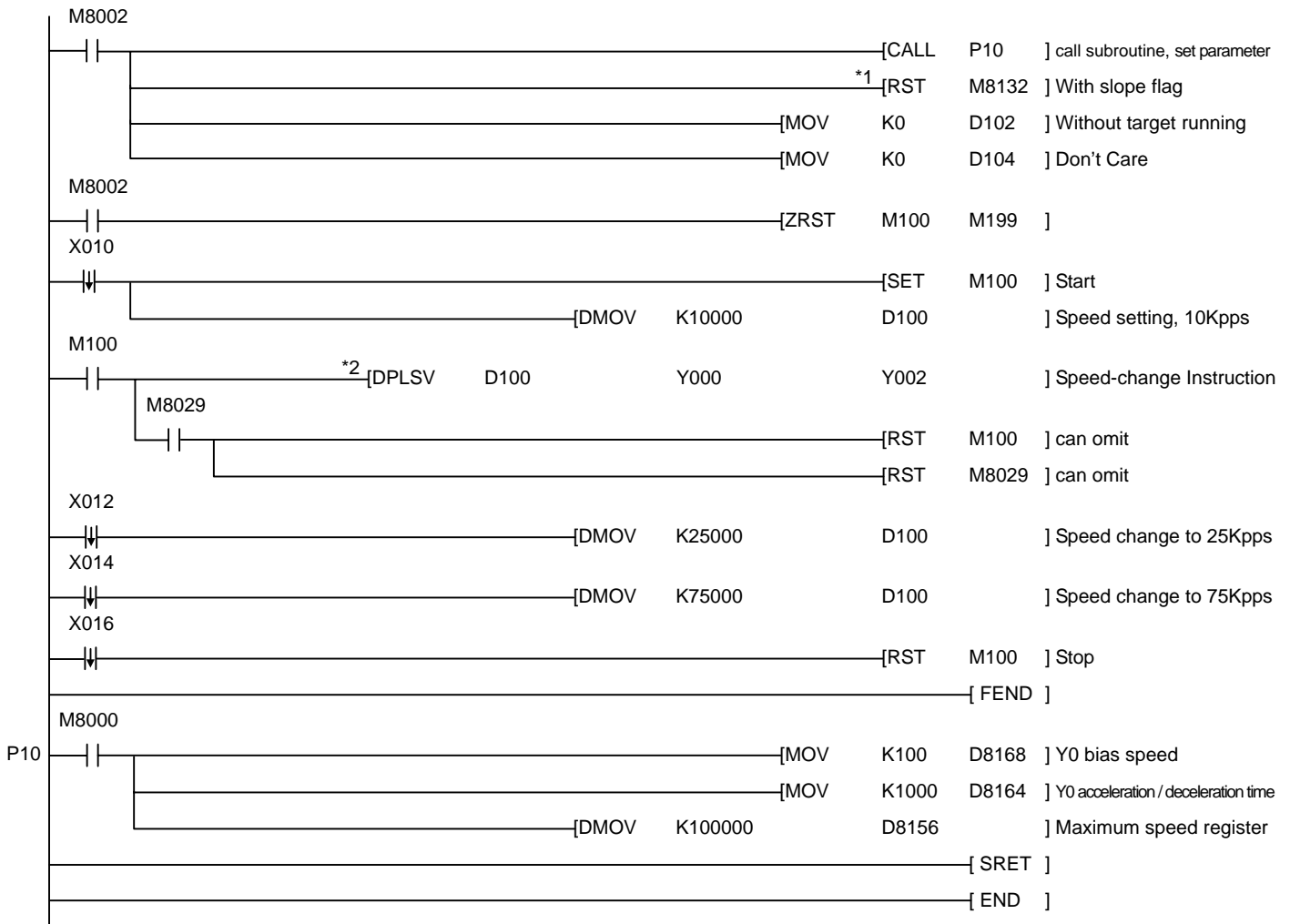

### Note:

\*1: M8132=0 With slope running(as Diagram I), M8132=1 Without slope running (as Diagram II)

\*2: The system of this example occupy D100, D102, D104, can't be other purpose.