

◎ Zero Return reverse mode – forward direction (from negative to positive coordinate) to search zero-point

◆Diagram :

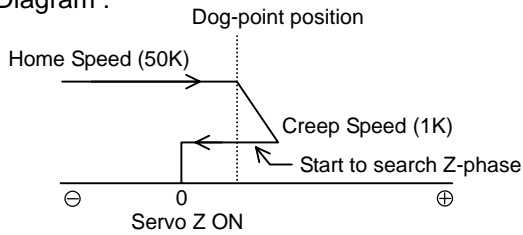

◆Action description

X12 ON, search Dog-point(forward direction) by 50K speed (Home Speed).

X6(DOG) ON, decelerate to 1K speed (Creep Speed) to search Zero-point(forward direction).

X6(DOG) OFF , (reverse) , Z-phase ON, stop.

◆Wiring

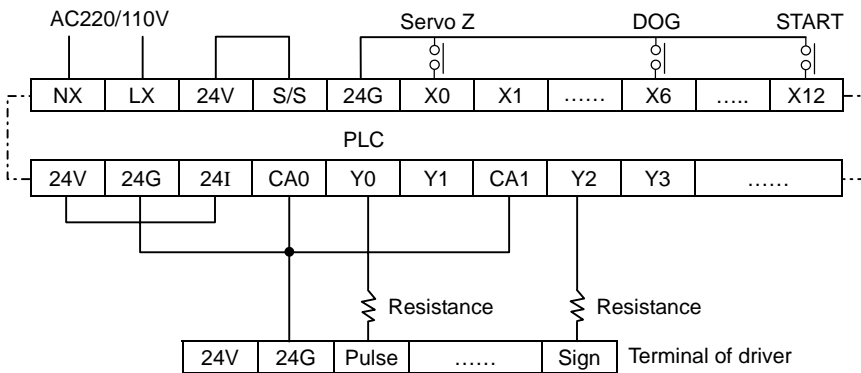

◆Program

