

◎ Zero Return forward mode – reverse (from positive to negative coordinate) to search zero-point

◆Diagram :

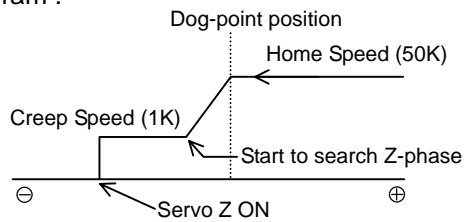

◆Action description

X12 ON, search dog-point (reverse) by 50K speed (Home Speed).

X6(DOG) ON, decelerate to 1K speed (Creep Speed) to search zero-point.

◆Wiring

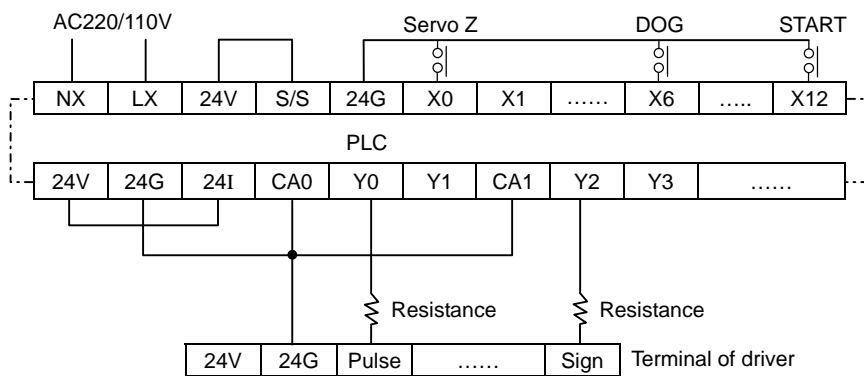

◆Program

