

◎ Zero Return forward mode – forward direction (from negative to positive coordinate) to search zero-point

◆Diagram :

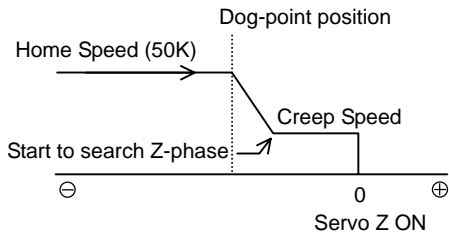

◆Action description

X12 ON, search Dog-point (forward direction) by 50K speed (Home Speed)

X6(DOG) ON, decelerate to 1K speed (Creep Speed) to search zero-point.

◆Wiring

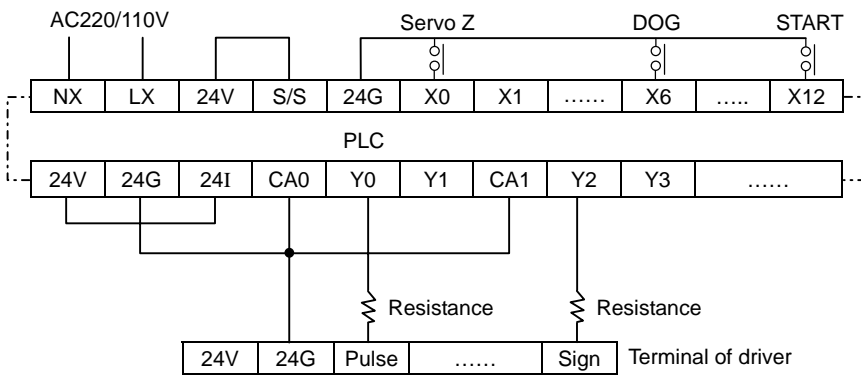

◆Program

