

EPPLC 手動正反轉(PLSR) – 與步進馬達

◆系統結構

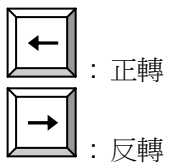

◆接線圖

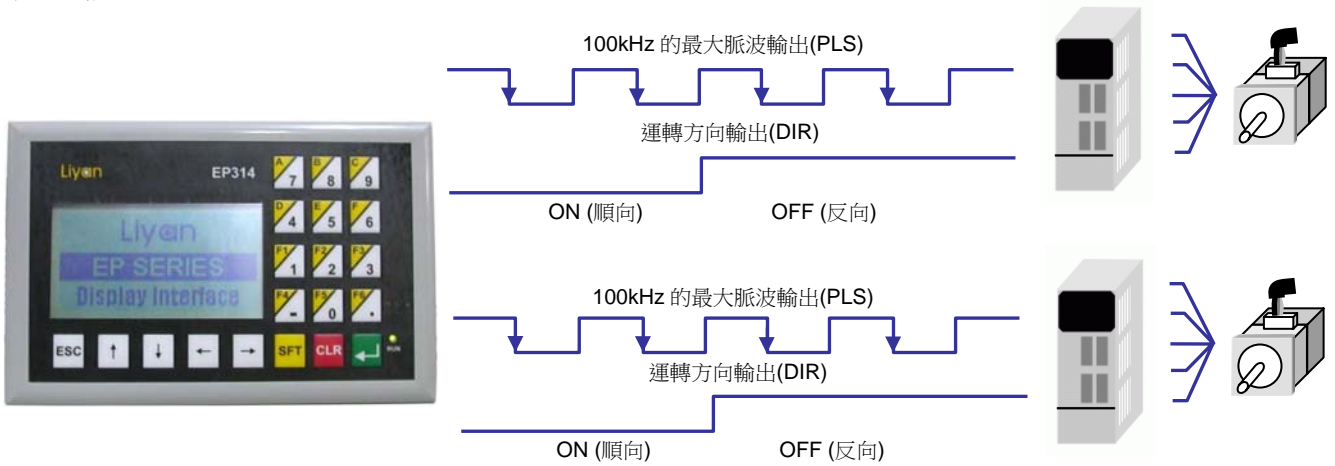
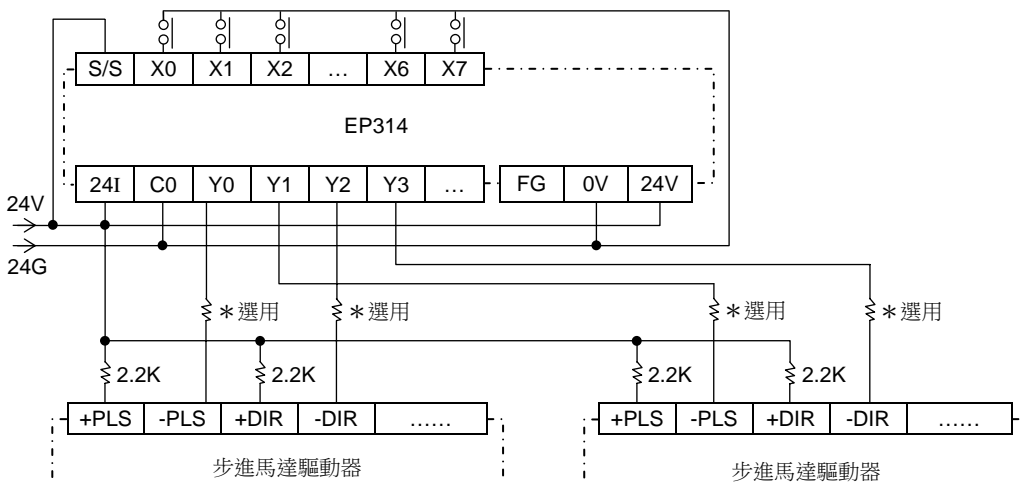

◆程式功能