

EPPLC 手动正反转(PLSR) – 与伺服马达

◆系统结构

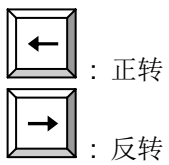

◆接线图

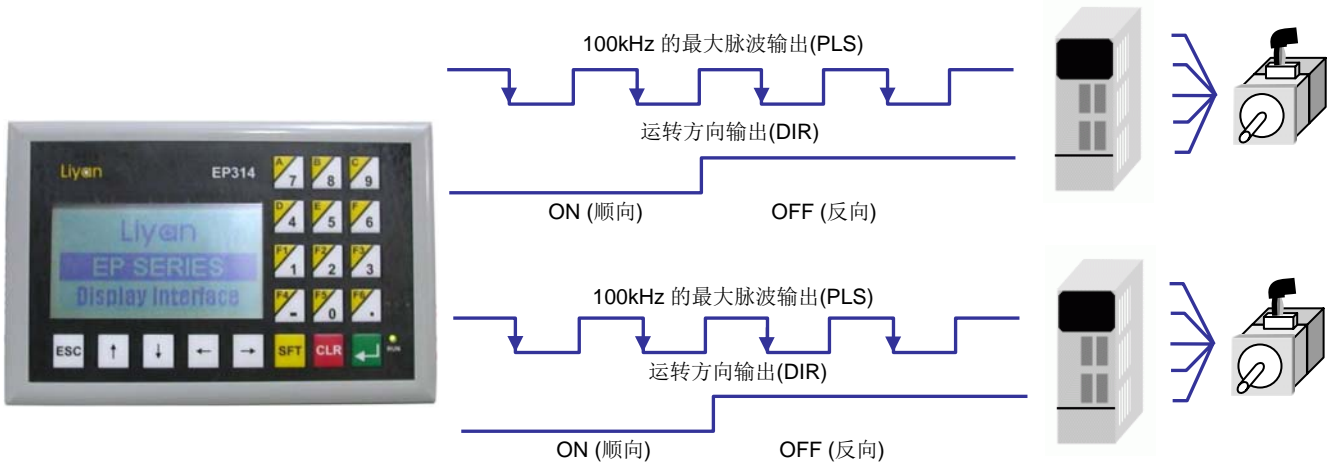
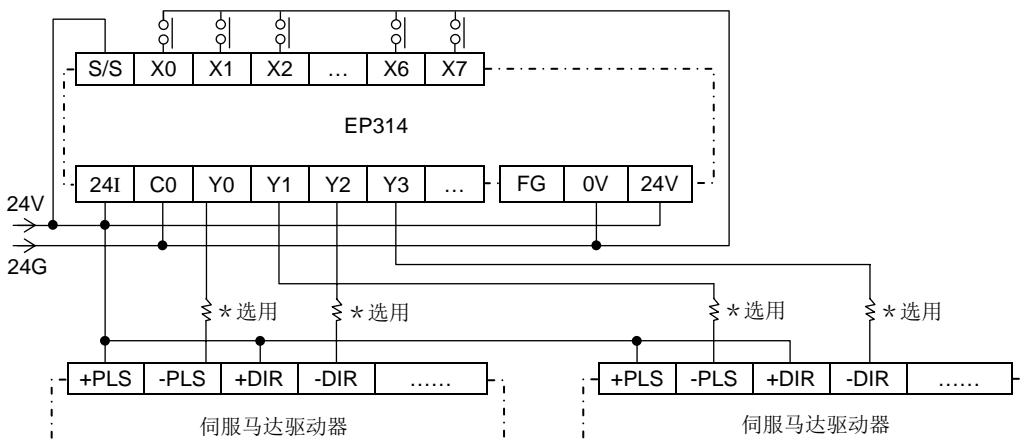

◆程序功能