

# Zero Return : Forward mode reverse direction – Stepping motor

## ◆Wiring

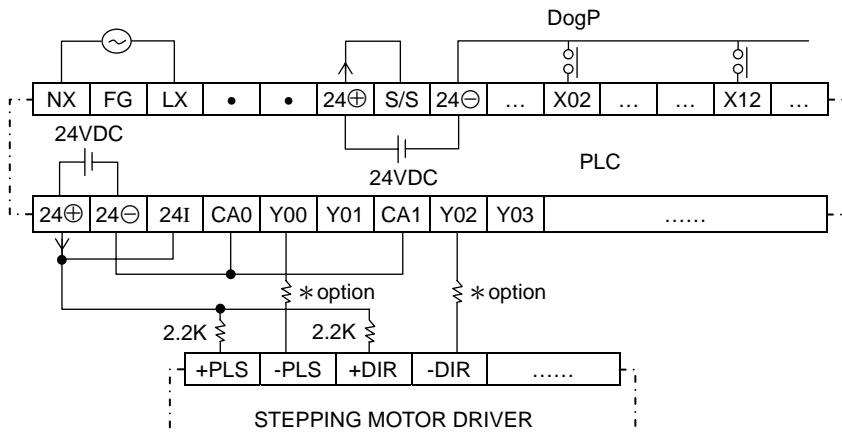

## ◆Action

<First direction reverse>

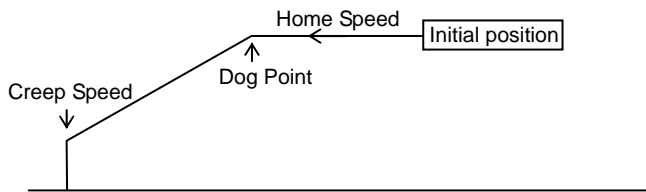

## ◆Sample Program

