

# Zero Return : Forward mode forward direction – Stepping motor

## ◆Wiring

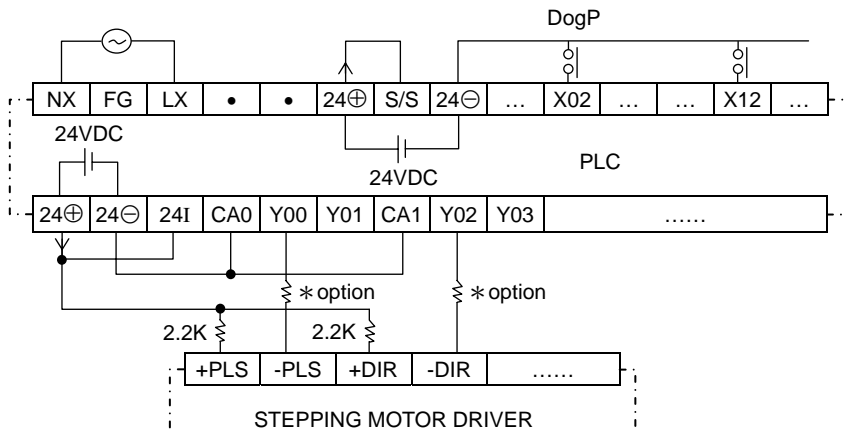

## ◆Action

<First direction forward>

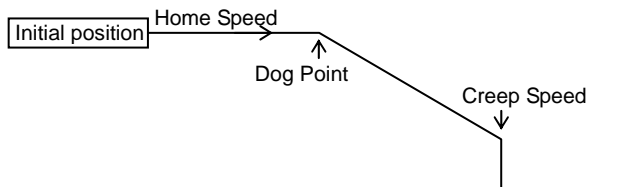

## ◆Sample Program

