

J series DPLSR [G28] : Zero return – Initial direction reverse (the number of times to look for Z phase is 0)

◆ Wiring diagram
100~240VAC 50/60Hz

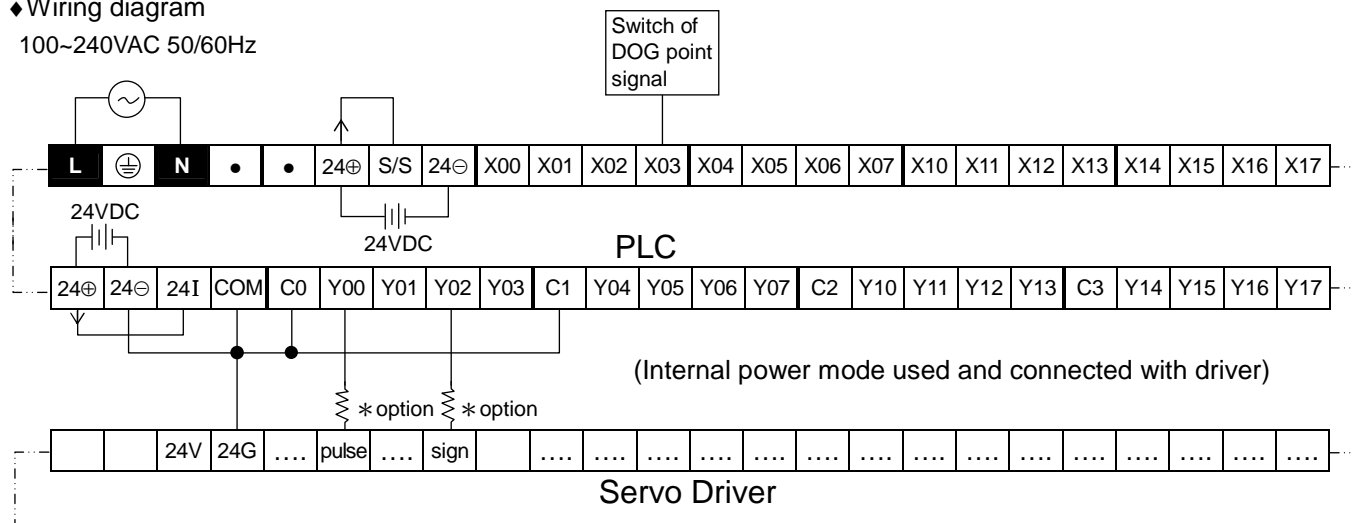

◆ Program exposition

M500 ON, looks for DOG signal through 10K speed (reverse)

X3(DOG) ON falling edge effective, decelerates to bias speed 100pps to look for zero-point signal (forward)

X3(Servo Z) ON falling edge effective, does not look for Z phase, then stop (Servo Z=0)

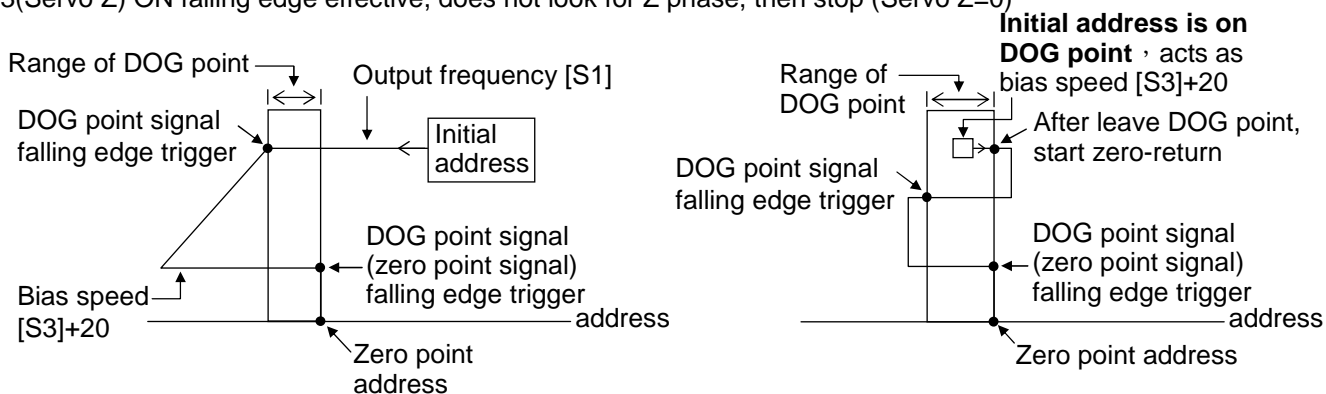

◆ About sample program, please refer to next page

◆ Sample program

