

# J series DPLSR [G28] : Zero return – Initial direction forward (the number of times to look for Z phase is 0)

◆ Wiring diagram  
100~240VAC 50/60Hz

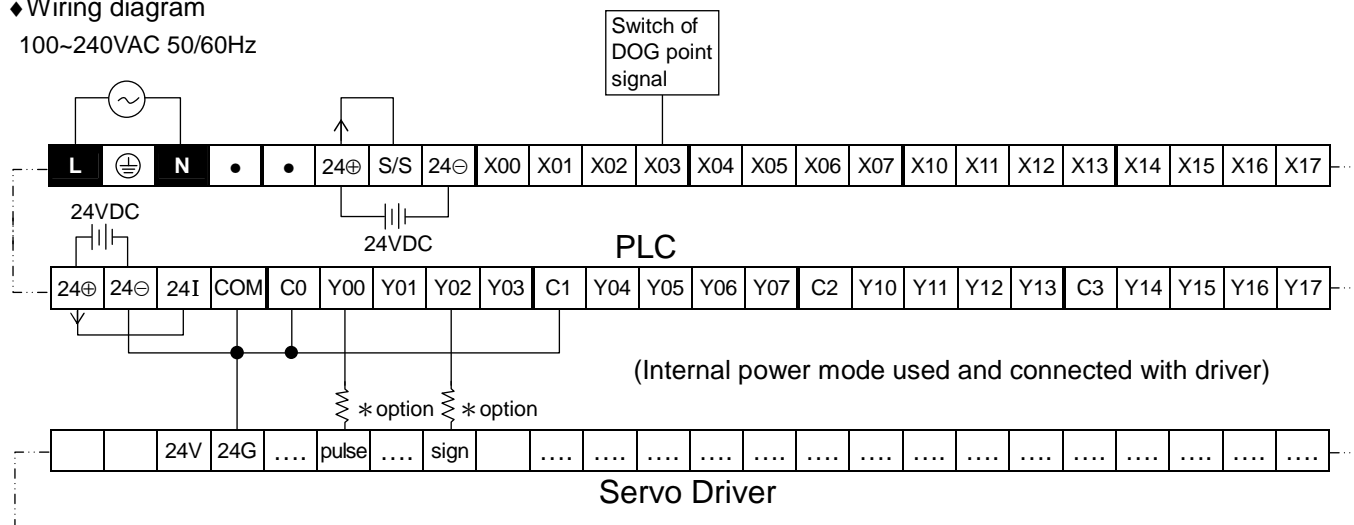

◆ Program exposition

M500 ON, looks for DOG signal though 10K speed (forward)

X3(DOG) ON falling edge effective, decelerates to bias speed 100pps to look for zero-point signal (reverse)

X3(Servo Z) ON rising edge effective, does not look for Z phase, then stop (Servo Z=0)

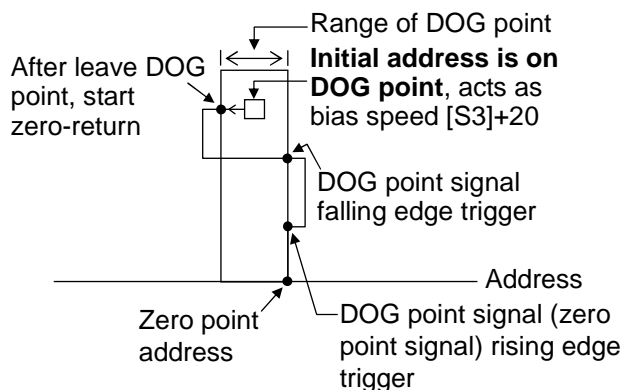
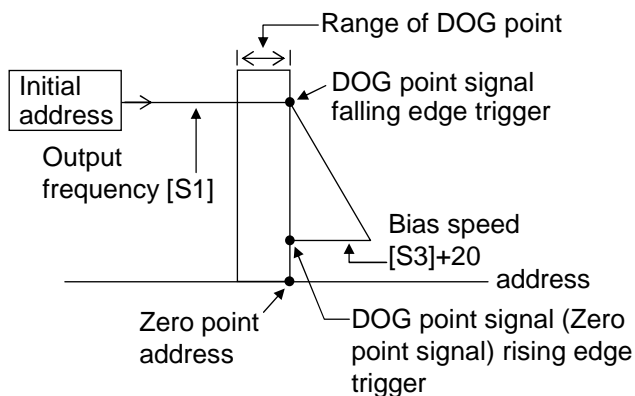

◆ About sample program, please refer to next page

◆ Sample program

