

J series DPLSR [G28] : Zero return – Initial direction forward (the number of times to look for Z phase is 3)

◆ Wiring diagram
100~240VAC 50/60Hz

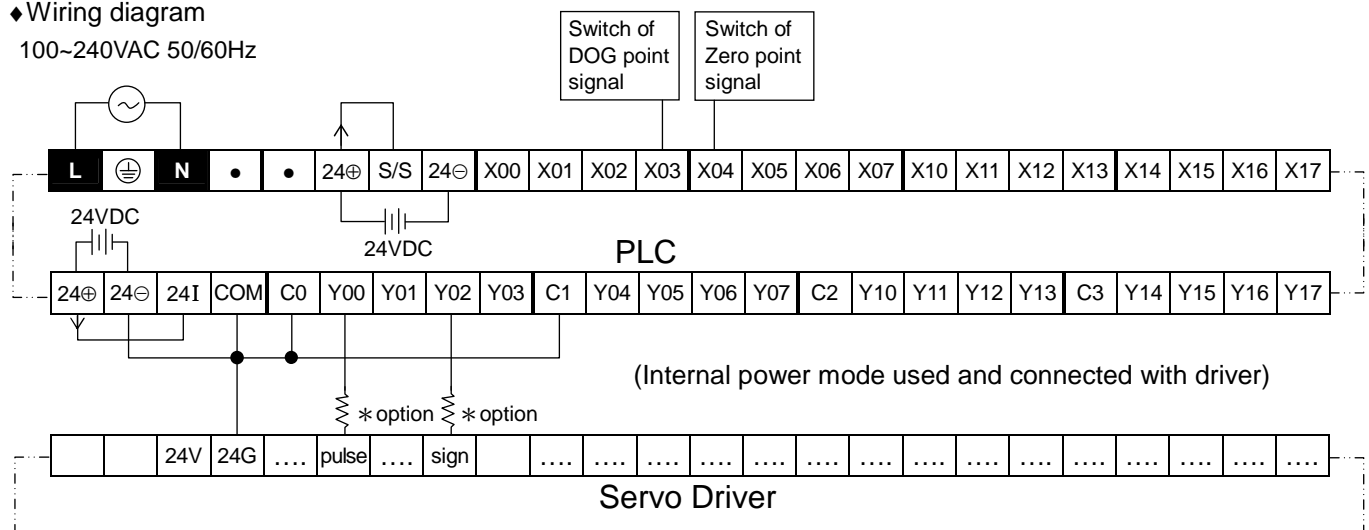

◆ Program exposition

M500 ON, looks for DOG signal through 10K speed (forward)

X3(DOG) ON rising edge effective, decelerates to 100pps to look for zero-point signal (forward)

X4(Servo Z) ON rising edge effective, after looking for (Servo Z) three times, then stops

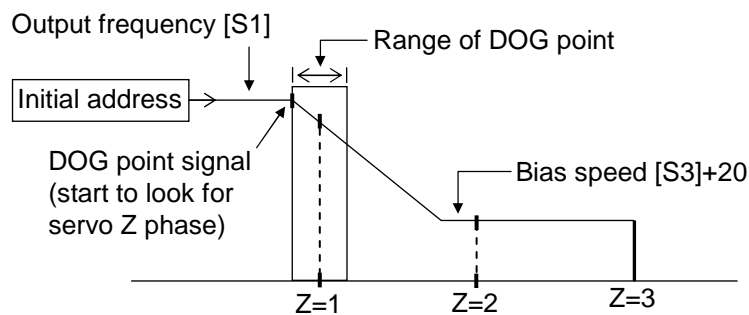

◆ About sample program, please refer to next page

◆ Sample program

