

# J series DPLSR [G06] : Ratio follow command

◆Wiring diagram  
100~240VAC 50/60Hz

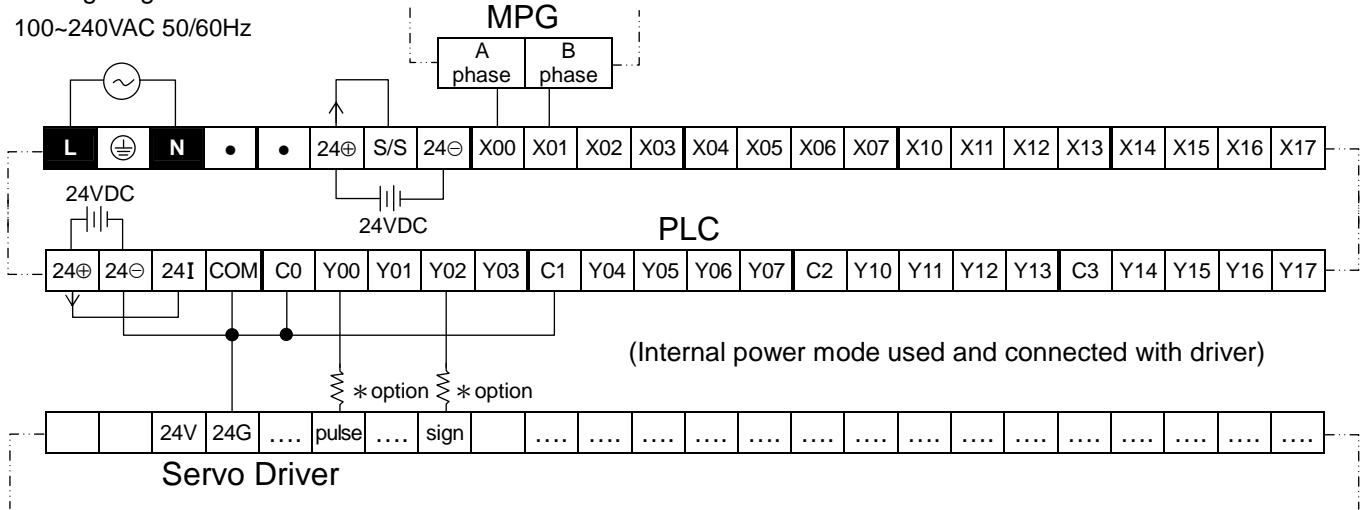

◆Program exposition  
After PLC turns on one scan-time, starts Ratio follow. Follows signal of X0 and X1 through electronic gear numerator 1 and denominator 5.  
During following, numerator and denominator can be changed immediately (numerator ≤ denominator )

◆Sample program

