

# J series DPLSR [G00] : Single position

◆ Wiring diagram  
 100~240VAC 50/60Hz

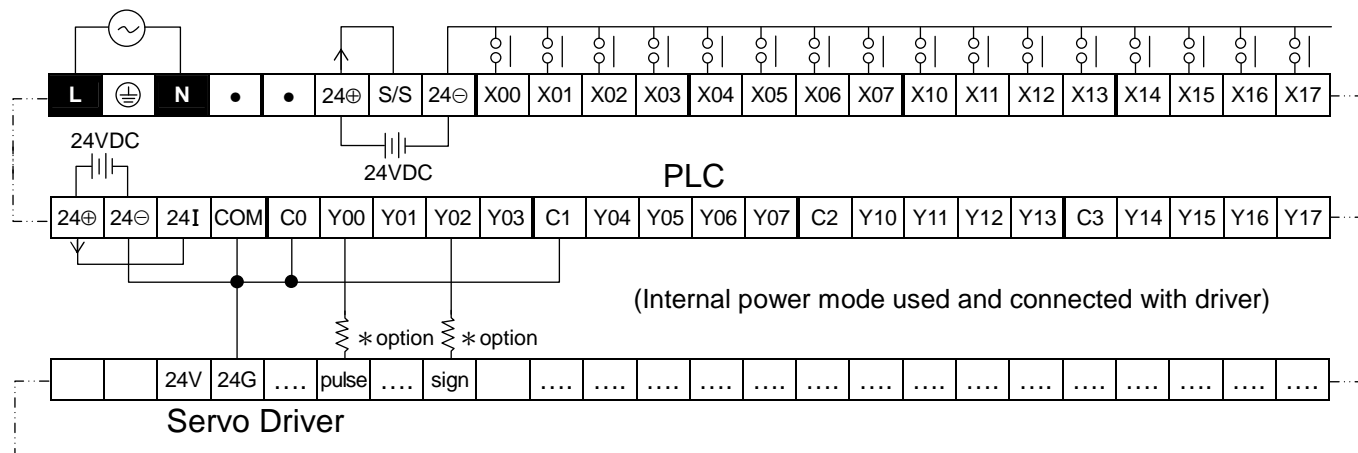

◆ Program exposition  
 M500 ON, outputs 10,000 pulses by 10K speed, then stops

◆ About sample program, please refer to next page

◆ Sample program

