

J series DPLSR : Zero return – forward mode touch software limit switch, stay one second, then reverse

◆ Wiring diagram

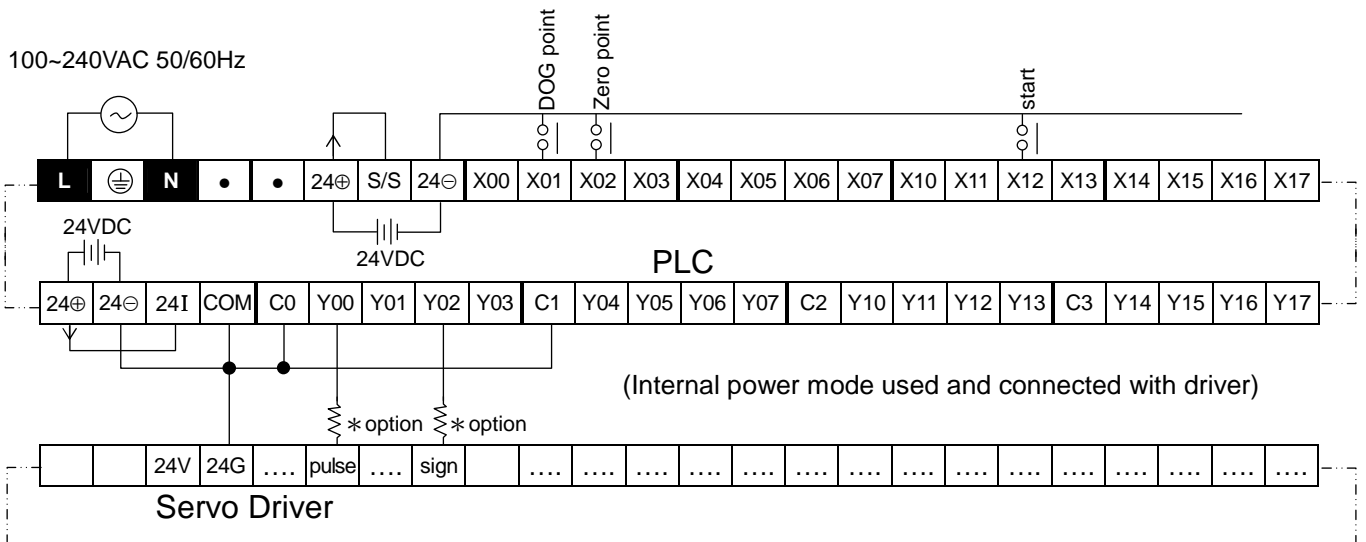

◆ Program exposition

X12 ON, start zero-return (initial direction is forward). If current absolute position of D1006 is more than range of K100000 ~ K-100000 (left and right limit) before completing zero-return, then reverse after waiting one second (restart action of zero-return).

◆ Sample program

