

J series DPLSR : During operation, multistage speed-change

◆ Wiring diagram

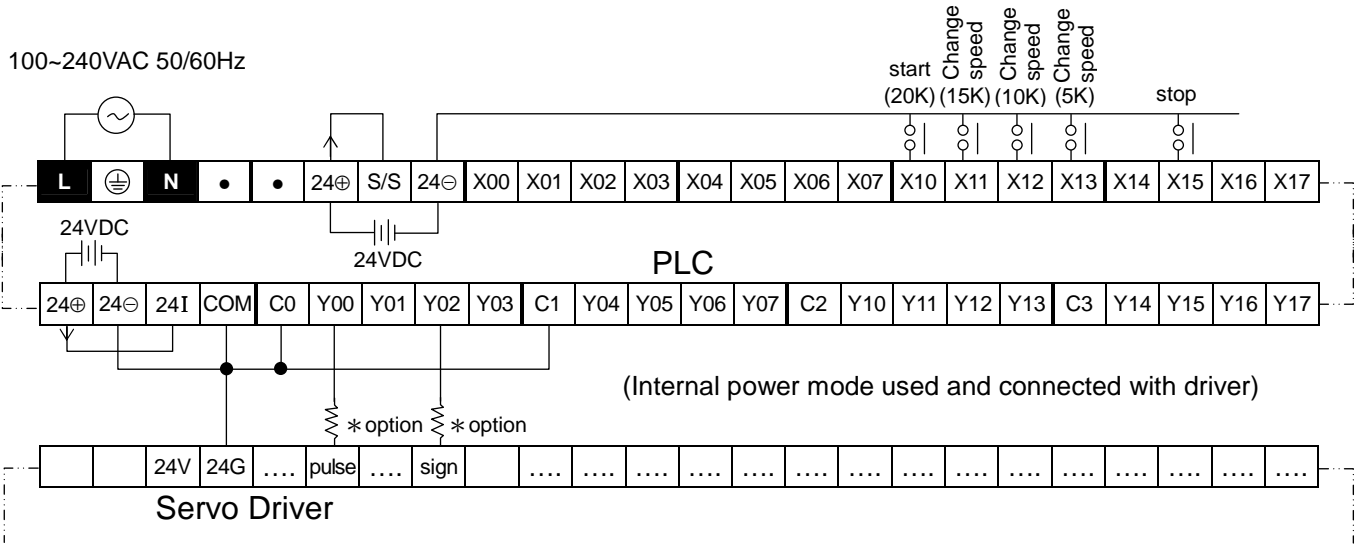

◆ Program exposition

- X10 falling edge: starts and operates by 20K speed
- X11 falling edge: changes speed (15K)
- X12 falling edge: changes speed (10K)
- X13 falling edge: changes speed (5K)
- X15 falling edge: stops operating

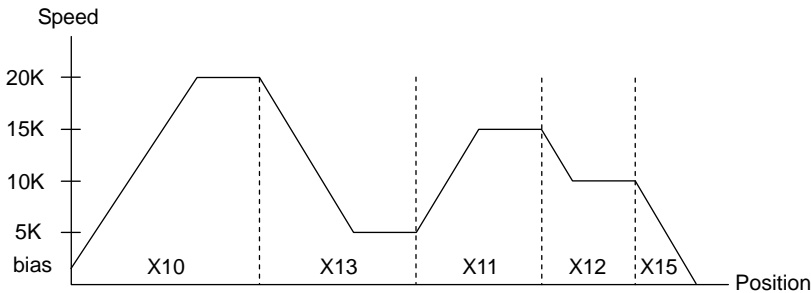

◆ About sample program, please refer to next page

◆ Sample program

