

## J series DPLSR : MPG

### ◆Wiring diagram

100~240VAC 50/60Hz

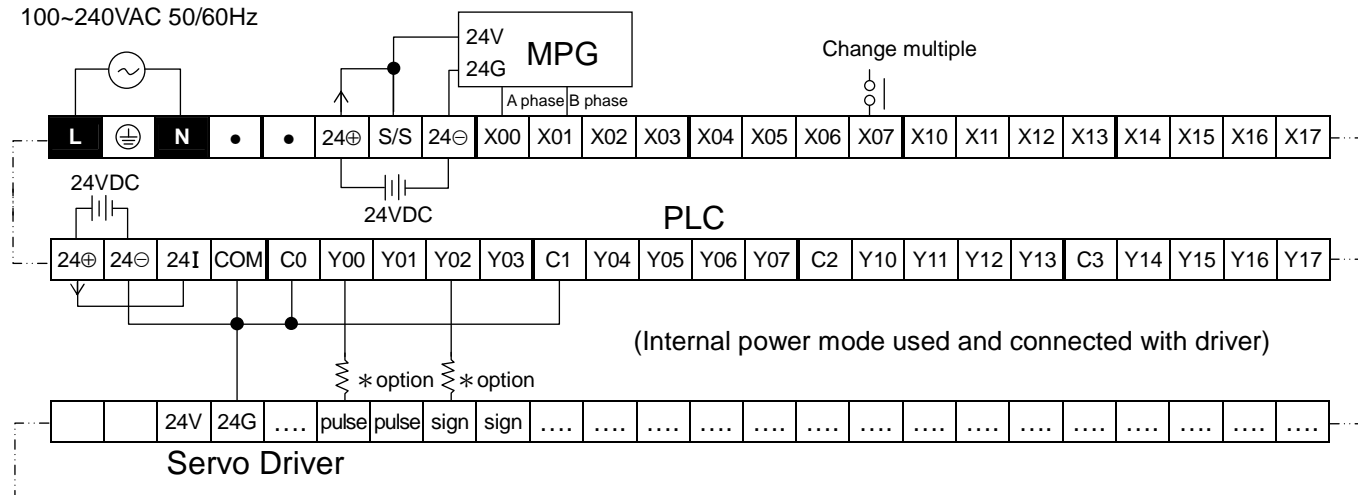

### ◆Program exposition

M500 ON: start MPG

X7 ON: multiply 10 (i.e. tenfold)

X7 OFF: multiply 100 (i.e. hundredfold)

### ◆ About sample program, please refer to next page

◆ Sample program

