

J series DPLSR : JOG forward/reverse

◆ Wiring diagram

100~240VAC 50/60Hz

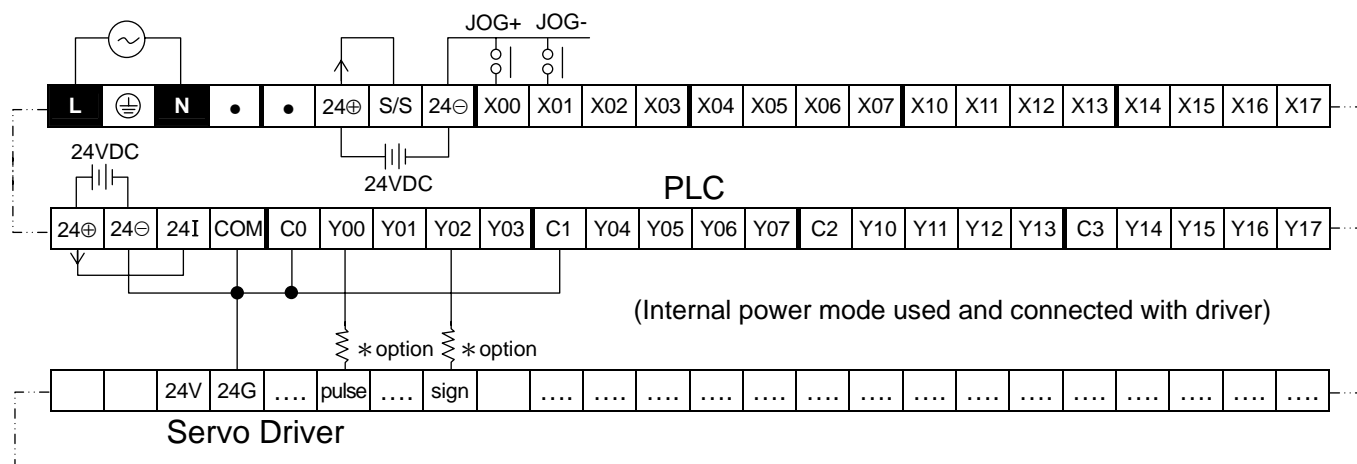

◆ Program exposition

X0 ON, start forward mode (speed 10K)

X1 ON, start reverse mode (speed 10K)

◆ About sample program, please refer to next page

◆ Sample program

